

Installation Guide

Saturn Plus Series

Applicable Model(s): Saturn-S1000 Plus, Saturn-S1200 Plus

Version: 1.0

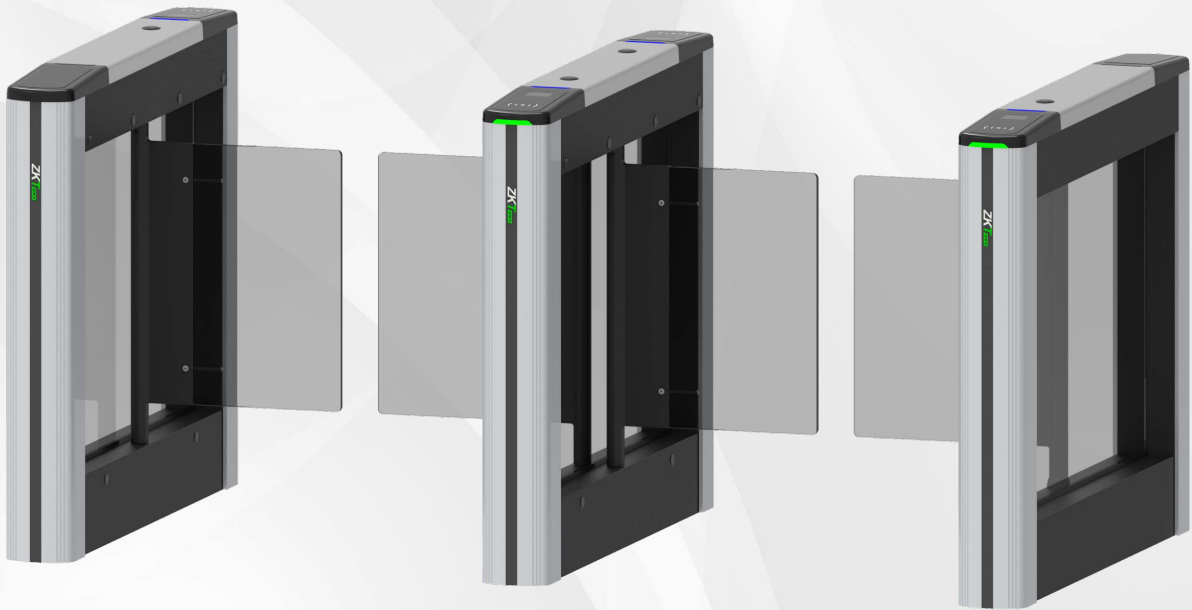

1 Overview

Saturn-S1000 Plus

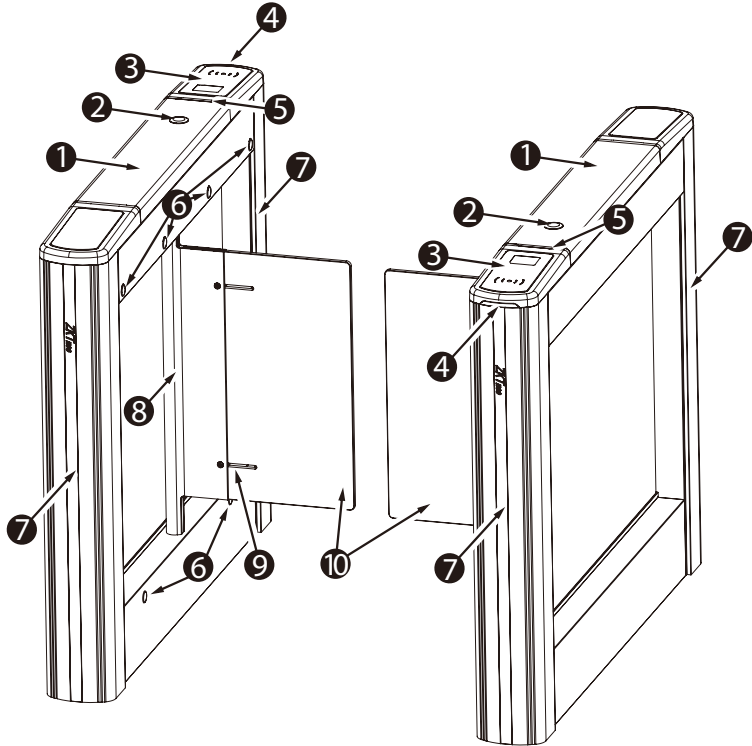

Saturn-S1200 Plus

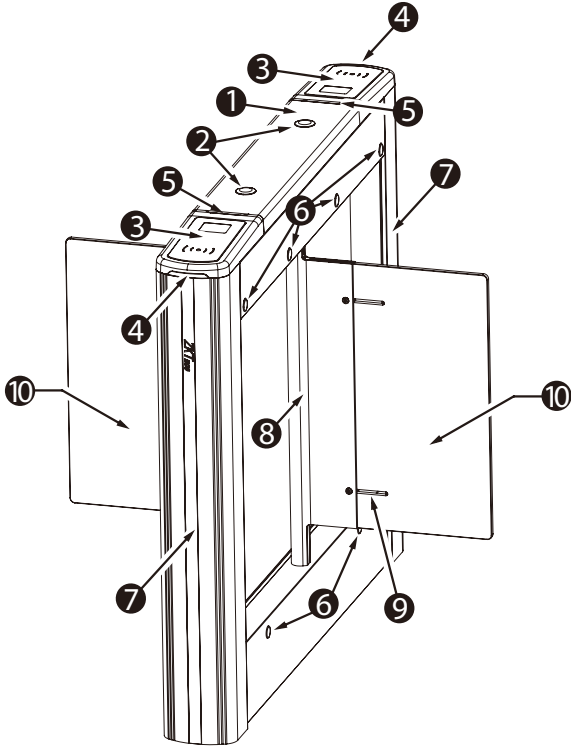

- ① Top Lid
- ② Reserve Mounting Hole (for Face Device)
- ③ Verification Area
- ④ Visual Indicator
- ⑤ Traffic Indicator
- ⑥ Infrared Sensor
- ⑦ Side Lid
- ⑧ Core Component
- ⑨ Adjustable Mounting Holes (Adjustable range: 75 mm)
- ⑩ Barrier Material

2 Dimensions

Saturn-S1000 Plus

Unit: mm

Front View

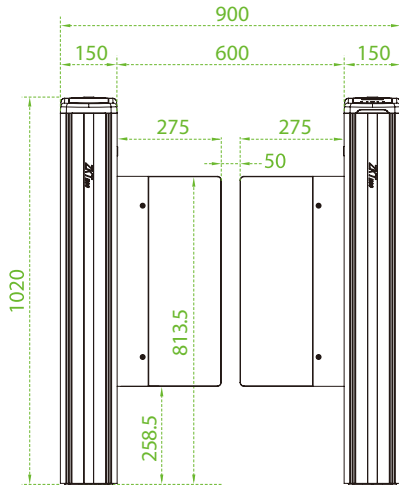

Side View

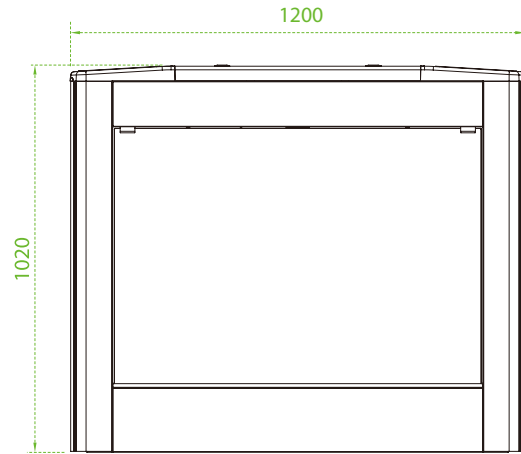

Top View

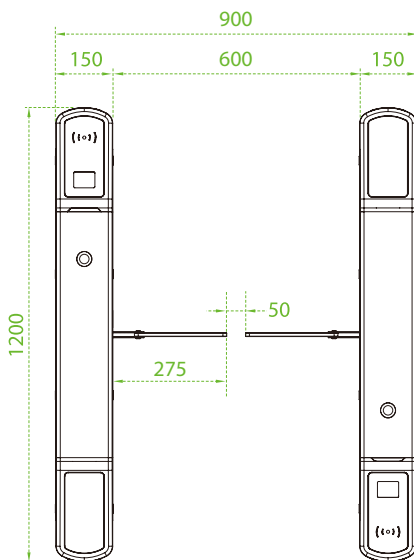

Bottom View

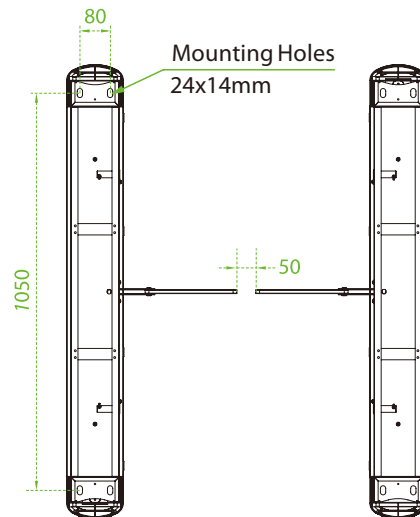

Saturn-S1200 Plus

Unit: mm

Front View

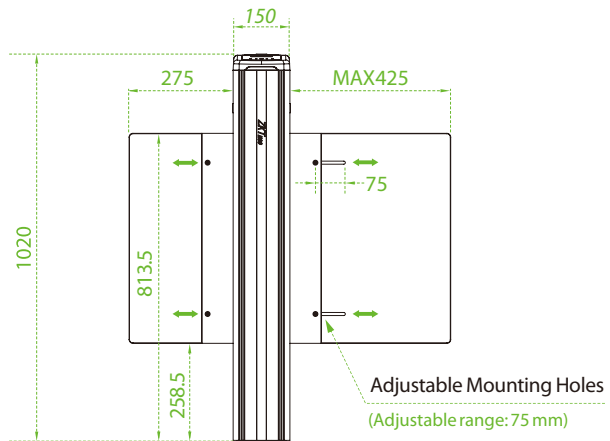

Side View

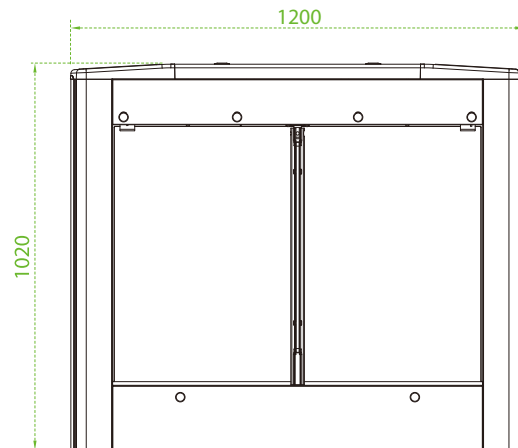

Top View

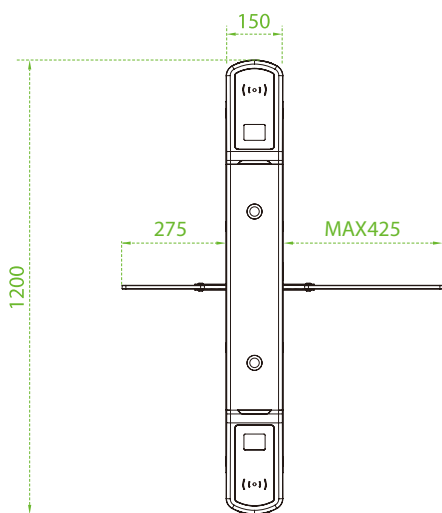

Bottom View

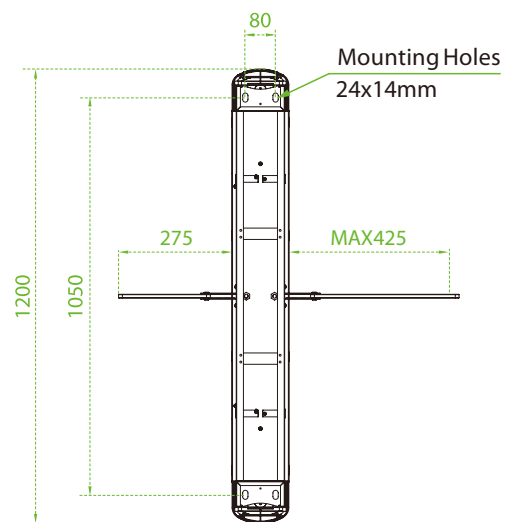

3 System Composition

The Saturn-S1000 Plus and Saturn-S1200 Plus can be combined to form a single, dual or multi-lane system, allowing the user to select the appropriate swing barrier size according to actual needs.

● Single-lane

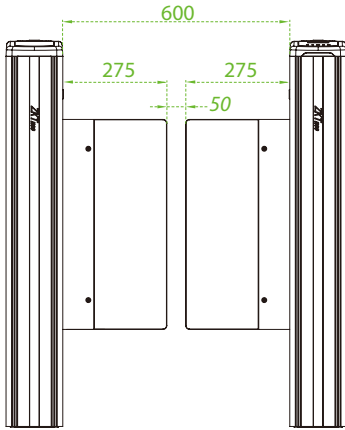

Standard Lane

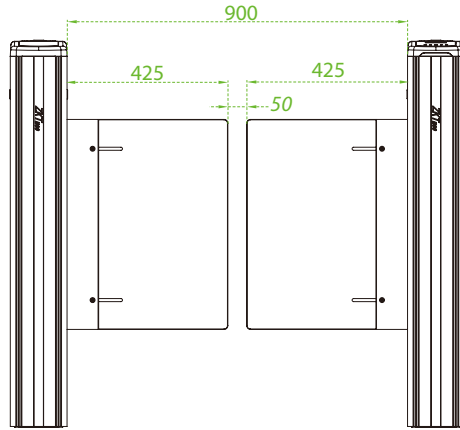

Wide Lane

● Dual-lane

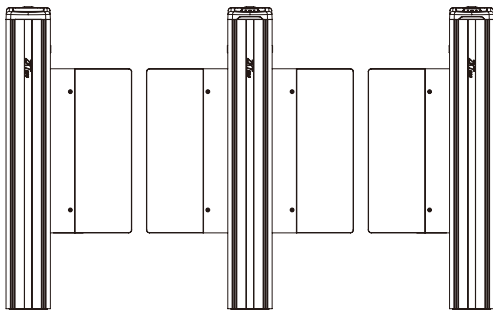

Standard Lane

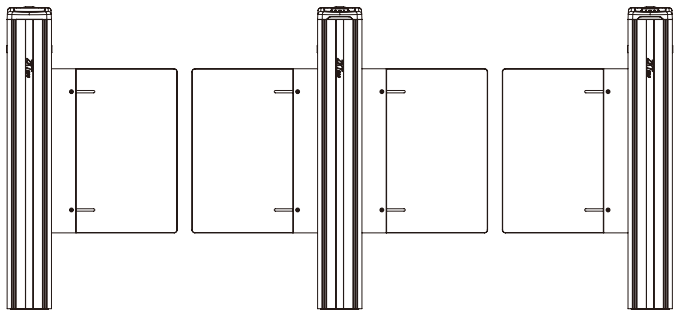

Wide Lane

● Multi-lane

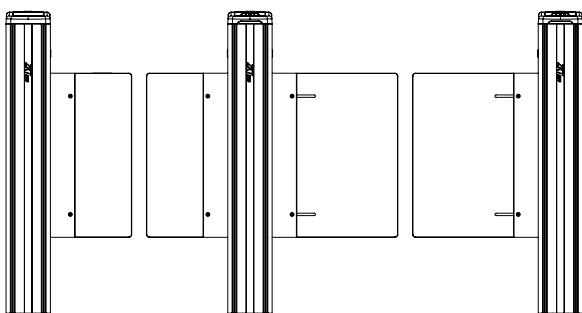

Standard Lane

...

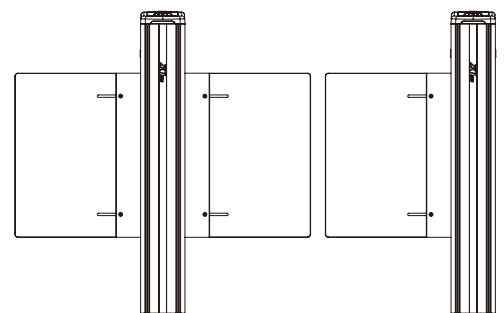

Wide Lane

4 Wiring

● Single-lane wiring

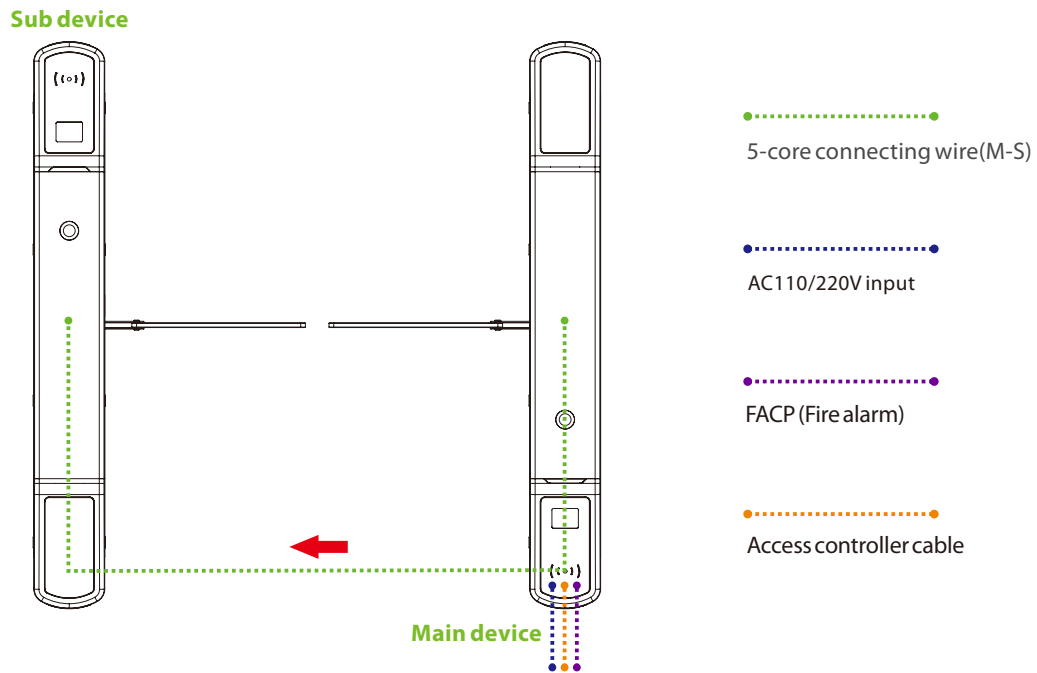

● Dual-lane wiring

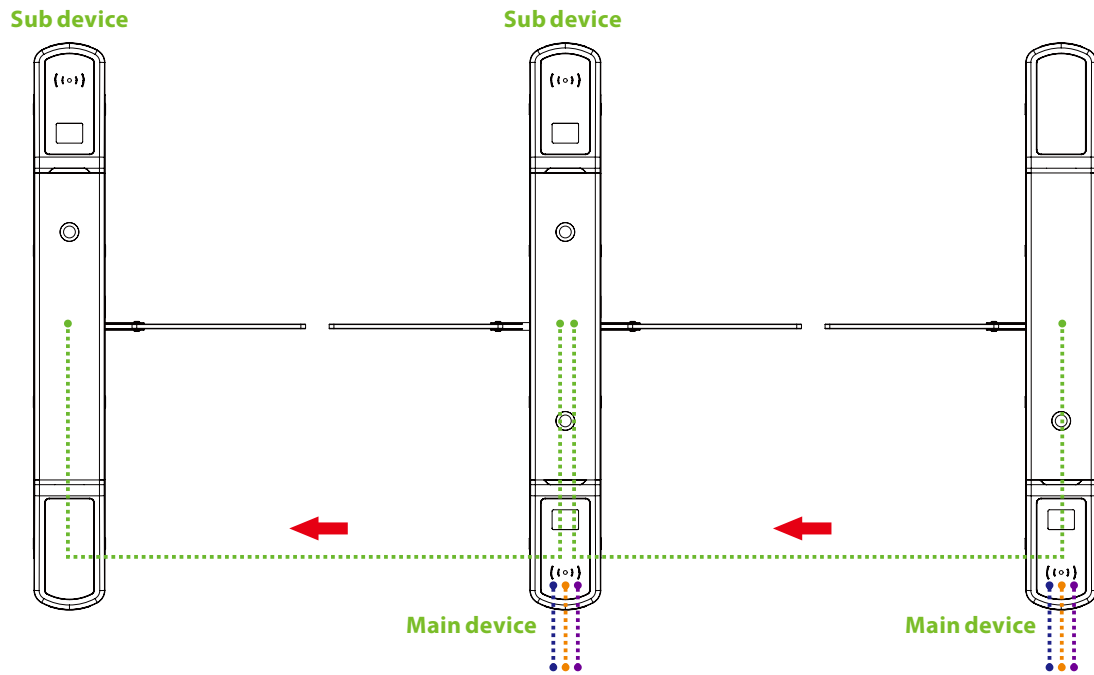

Remarks: The multi-lane wiring method is similar.

5 Installation Requirements

1. It is recommended that the turnstile must be installed on a horizontal solid platform with a height of **50mm to 100mm**.
2. It is recommended that the turnstile should not be used in the corrosive environment.
3. Make sure that the ground wire of the system is securely connected to avoid personal injuries or other accidents.
4. After installation, check if the connection has been done correctly at the connecting points of the ground wire, at the connector assemblies and wiring points of the circuits, as well as at each movable part of the turnstile. Any loose nuts, screws and other fasteners should be tightened in time to avoid any failures caused by long-time operations.

6 Installation Environment

1. Before installation begins, prepare installation tools, check the device and the accessories, and clear the installation base.
2. Make sure that the appliance is mounted on a concrete surface or other non-flammable surfaces.
3. The installation position of the turnstile depends on its size. A distance of **100mm** between the turnstile and the wall needs to be reserved for ease of opening the top lid of the turnstile to perform maintenance and adjustment. The reference figure is shown below:

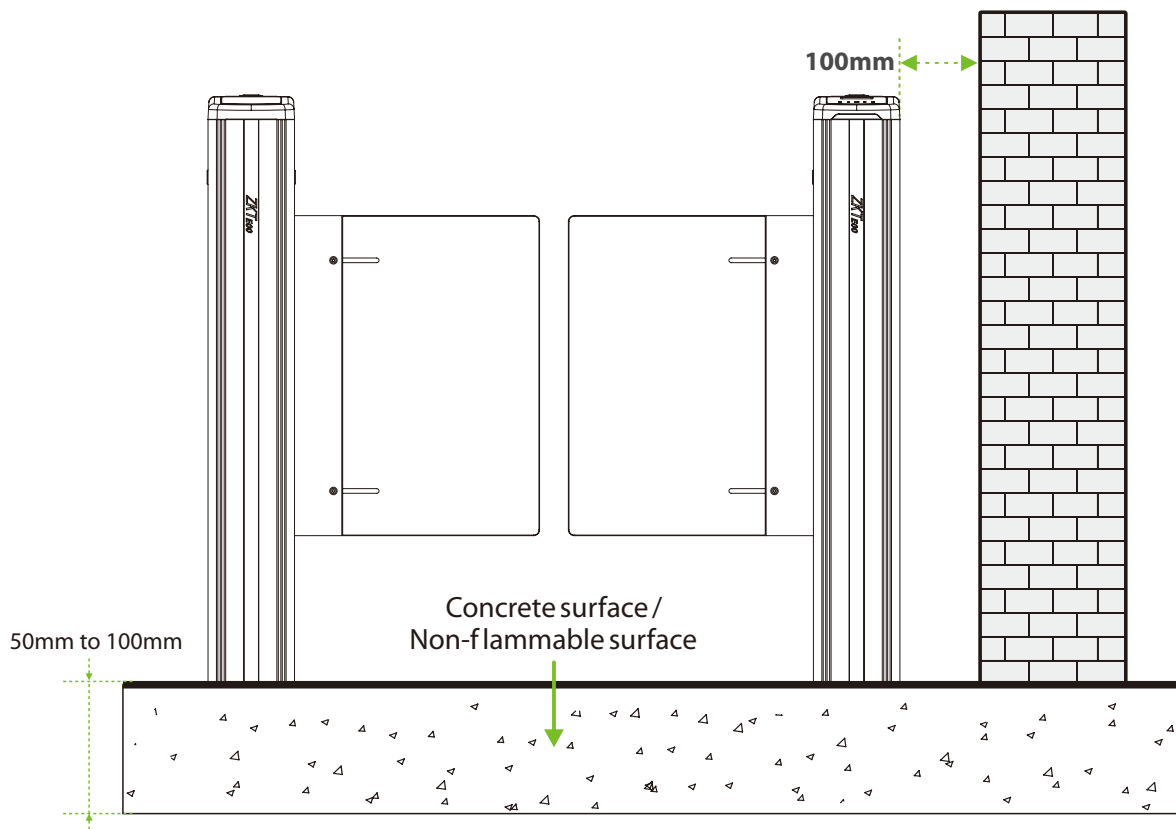

7 Installation Cabinet

Step 1 Remove the Top Lid and Push Up the Side Lid

1. Remove the four screws hidden under the top lid, then remove the top lid.

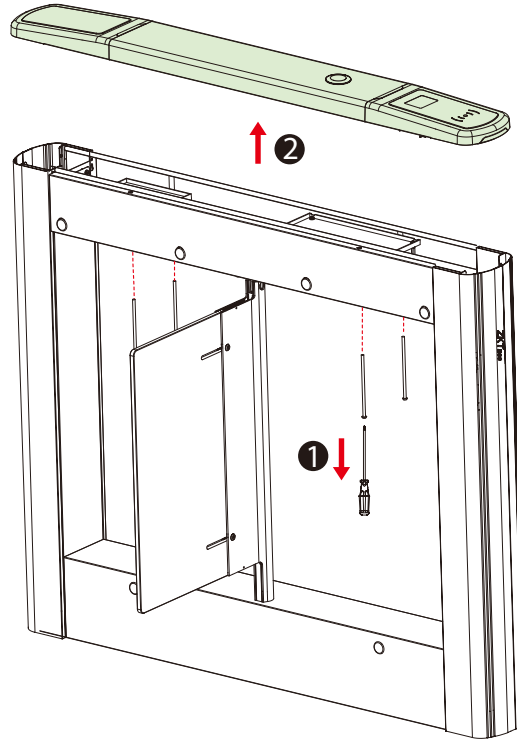

2. Push the side lid upward to expose the expansion screw mounting holes.

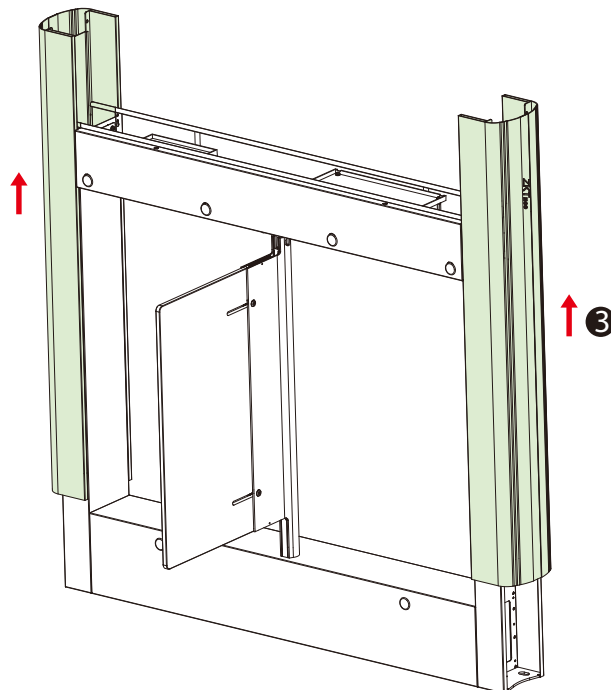

Step 2 Determine the Mounting Location

1. Please refer to the user's manual and complete the **power-on self test** operation before installation.
2. Then place the cabinet according to the mounting distances shown in the diagram below. Take care to measure the distance between the bottom inside walls of the cabinets on the entrance side and exit side of the channel and make sure that the measurements are consistent.

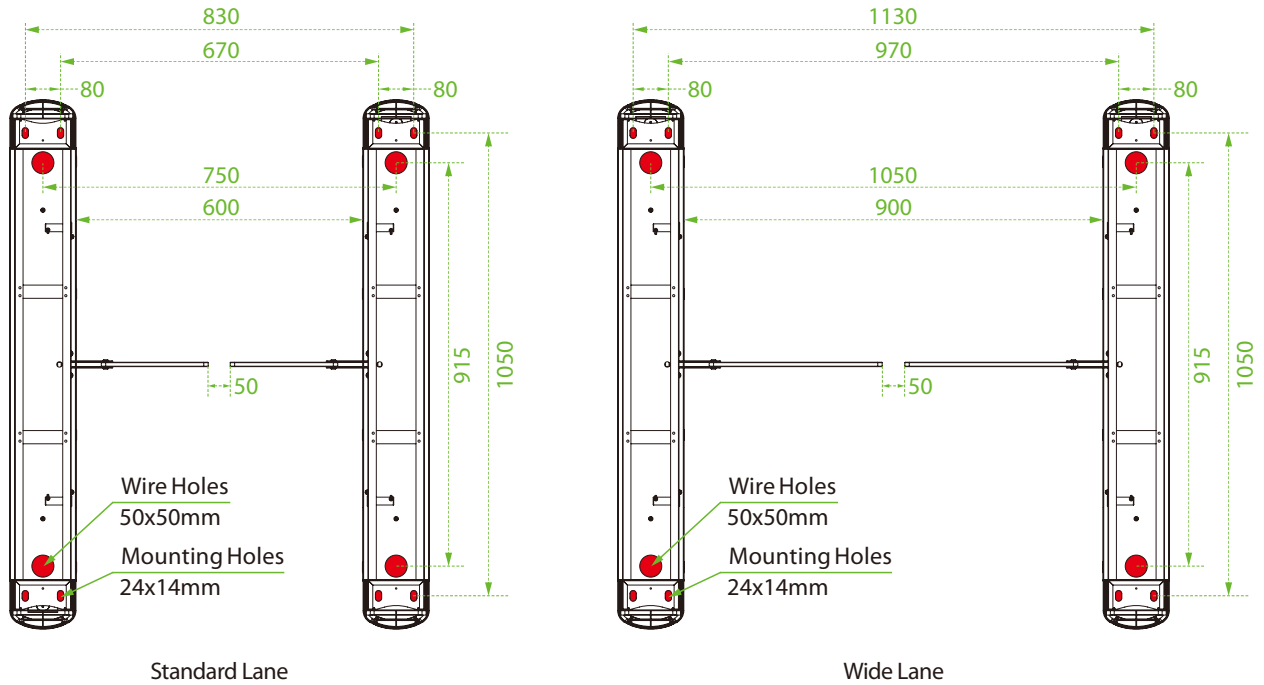

Step 3 Marker Position

Draw the location of the cabinet with a marker and mark each location of the mounting holes. There will be a total of four mounting holes and two wire holes per cabinet.

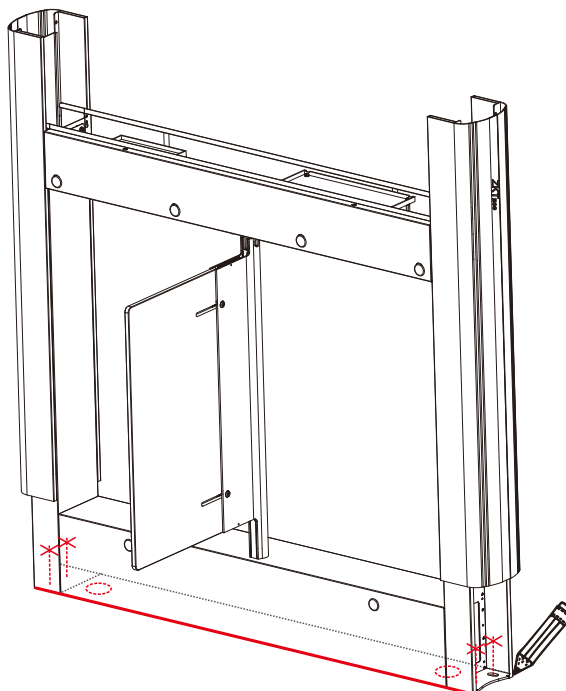

Step 4 Drill Holes and Place Bolts

1. Using a concrete drill bit, drill the mounting holes **60mm** in depth at the center of each marked location.
2. Then insert the bolts vertically into the mounting holes as shown at right.
3. Make sure the bolts are placed in place. Use a hammer to tap the bolts into place, if needed.

Place bolts into mounting holes

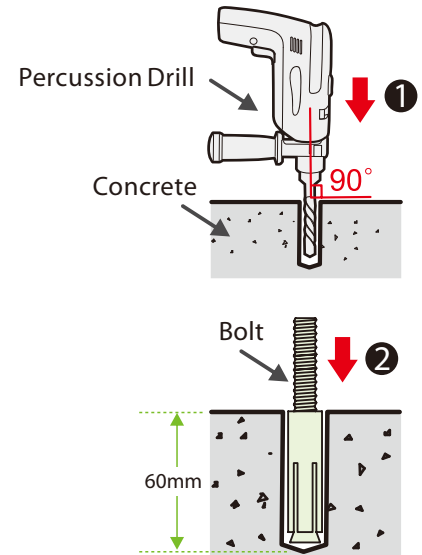
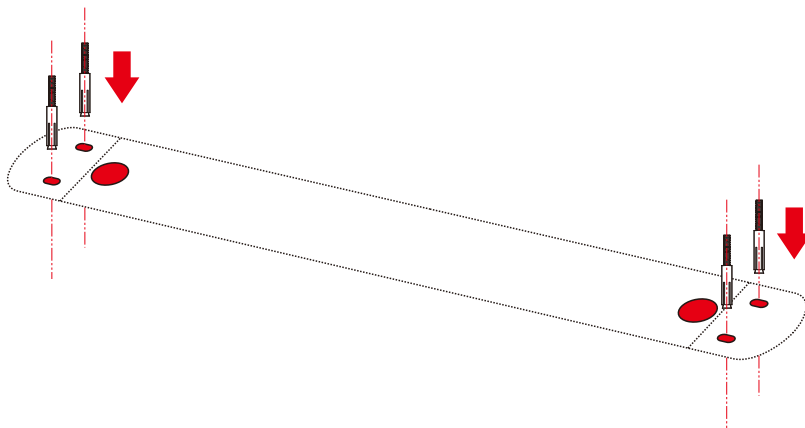

Step 5 Wireway Laying

1. Dig a recess of **50mm** depth between the wire holes on both sides of the channel with the dimensions shown below. Recesses can be dug at positions ① and ②.
2. Then lay two **25mm** diameter PVC pipes as shown below.
3. After threading the cable out of the PVC pipe, pour concrete to fix it in place.

Top View

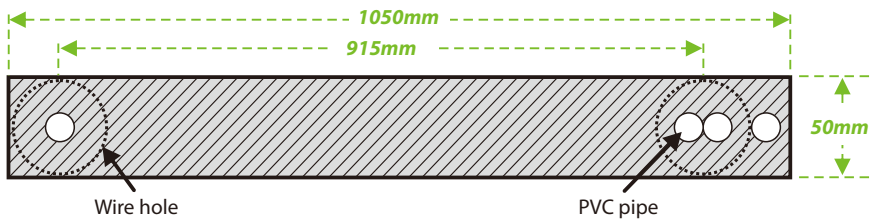

Side View

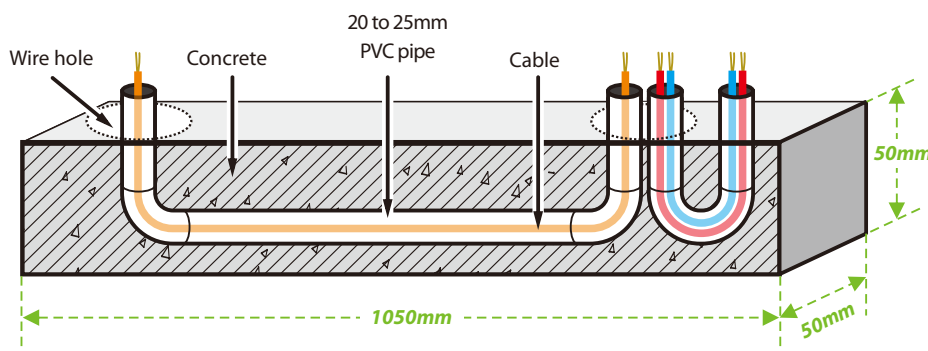
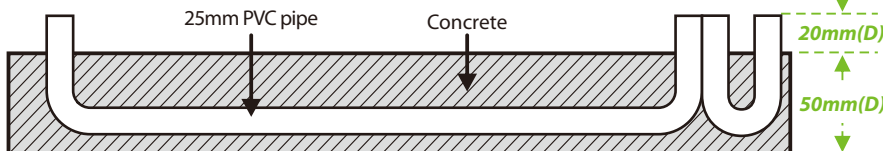

Position of the notch:

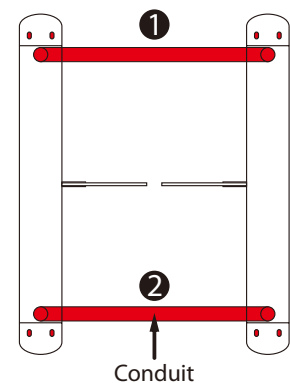

- ECU-panel connection wire
- Ethernet cable / Access control cable
- Power cable

Step 6 Fixed Cabinet

1. After laying the PVC pipe, place the cabinet alignment bolts back into the mounting position.
2. Then insert the four washers and nuts into the bolts one by one.
3. Tighten the nuts to hold the cabinet in place. Don't tighten it completely until after you're sure it won't move anymore. The finished result is shown below:

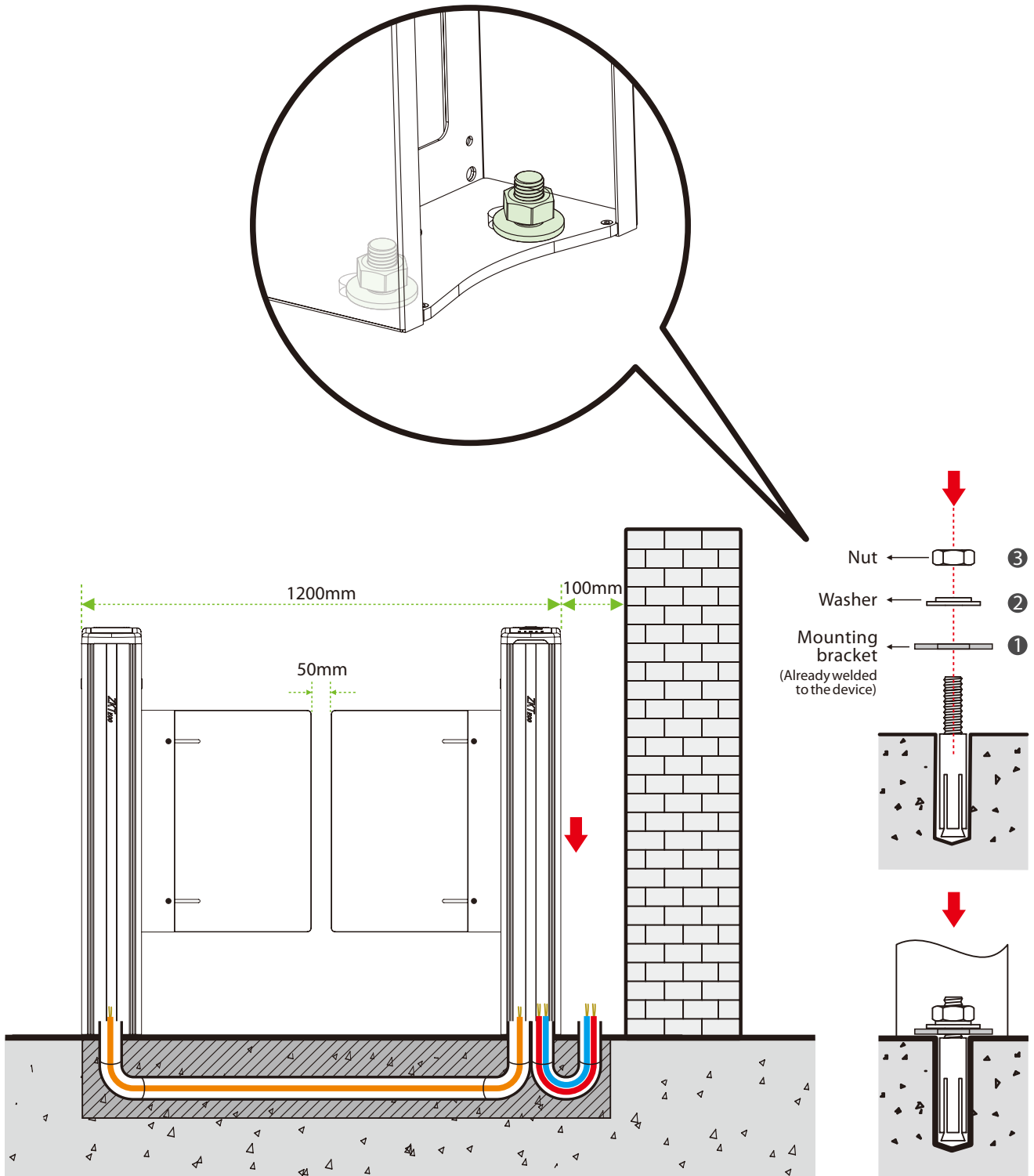

Step 7 Close the Top Lid and Side Lid

Close the top lid and side lid, then secure the top lid with screws.

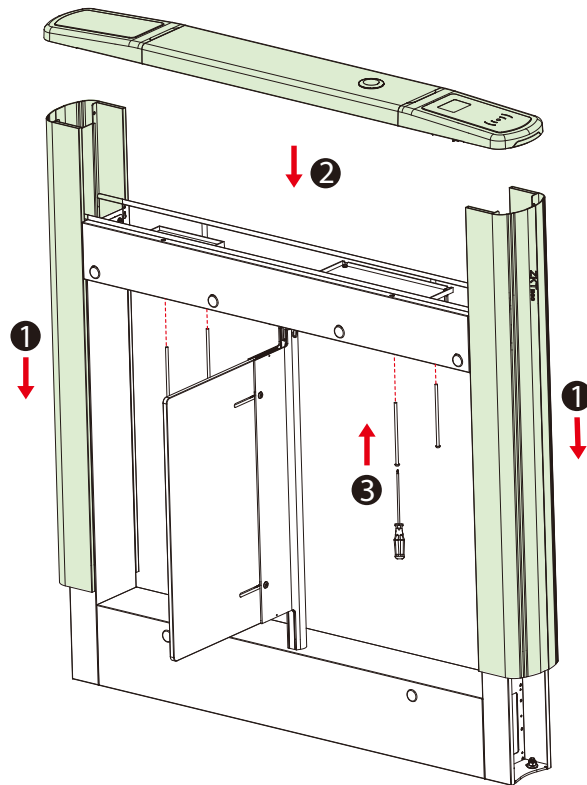

Step 8 Marking the Warning Line

1. It is recommended that warning lines be marked on the ground and used to alert users.
2. A warning line can alert users to wait outside the line until the previous user completes the verification process and passes through the turnstile.

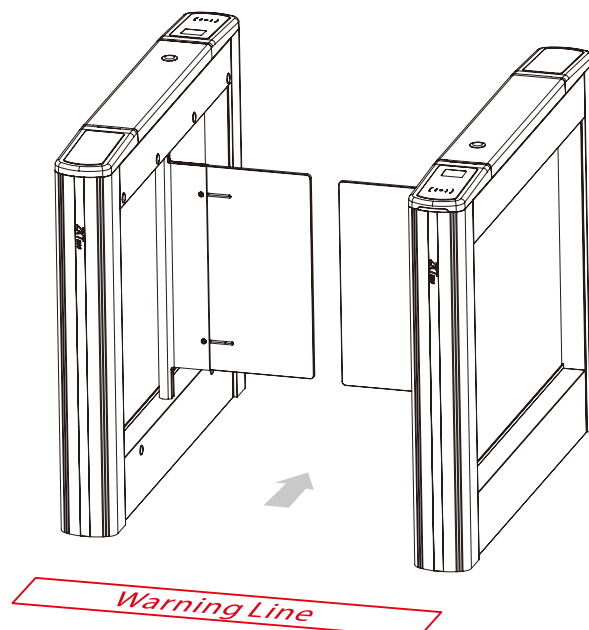

8 Wiring Diagram

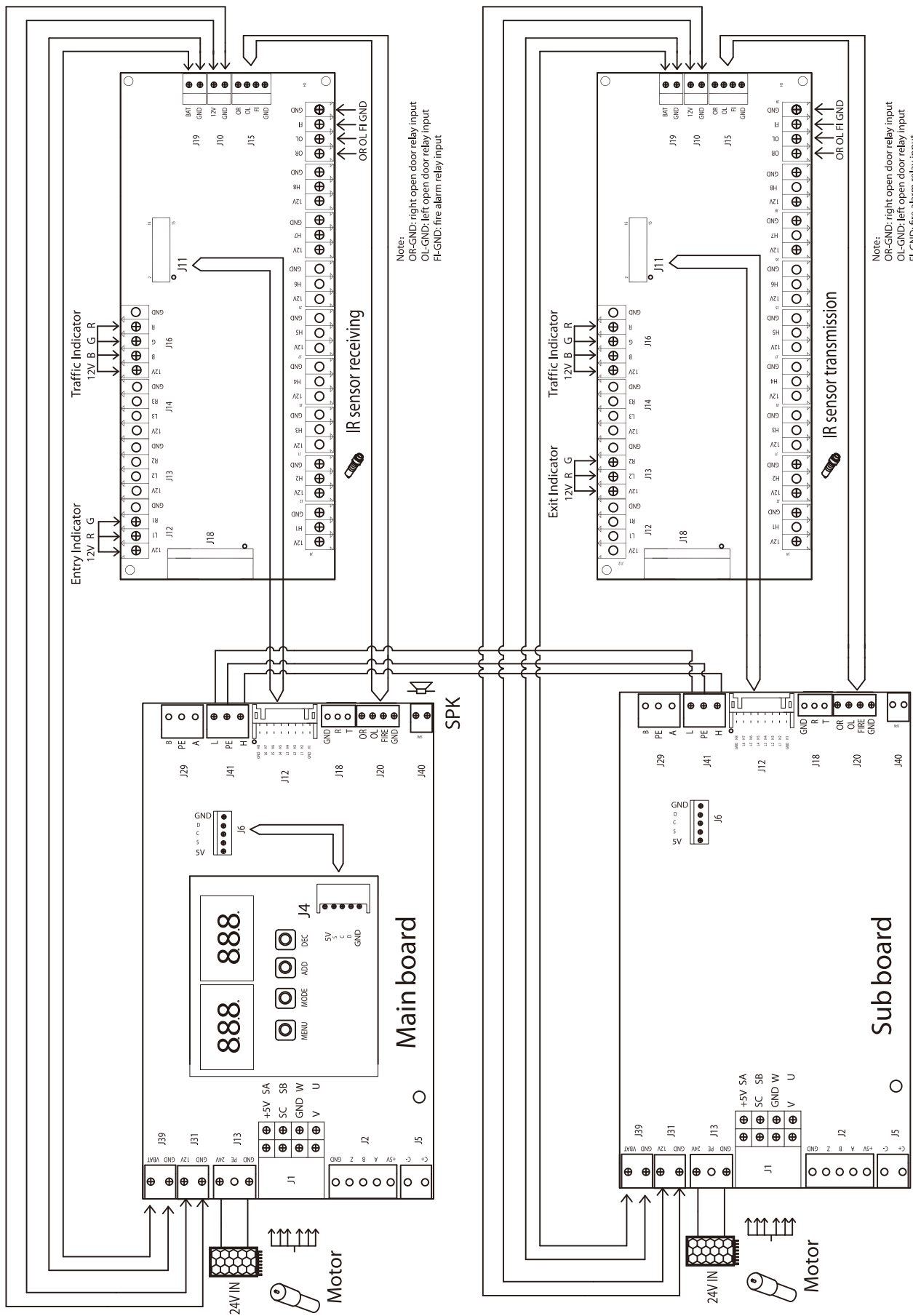

ZKTeco Biometrics India Pvt Ltd.

B-1, Khata No. 31, Devasandra Industrial Estate, Whitefield Main Road,
Beside Phoenix mall, Mahadevapura, Bengaluru-560048, Karnataka, India.

Phone : 080 6828 1342

Mail : sales@zkteco.in

Website : www.zkteco.in

